

# FIRST CLASS 3 FRONT LED PANEL 02\_2021

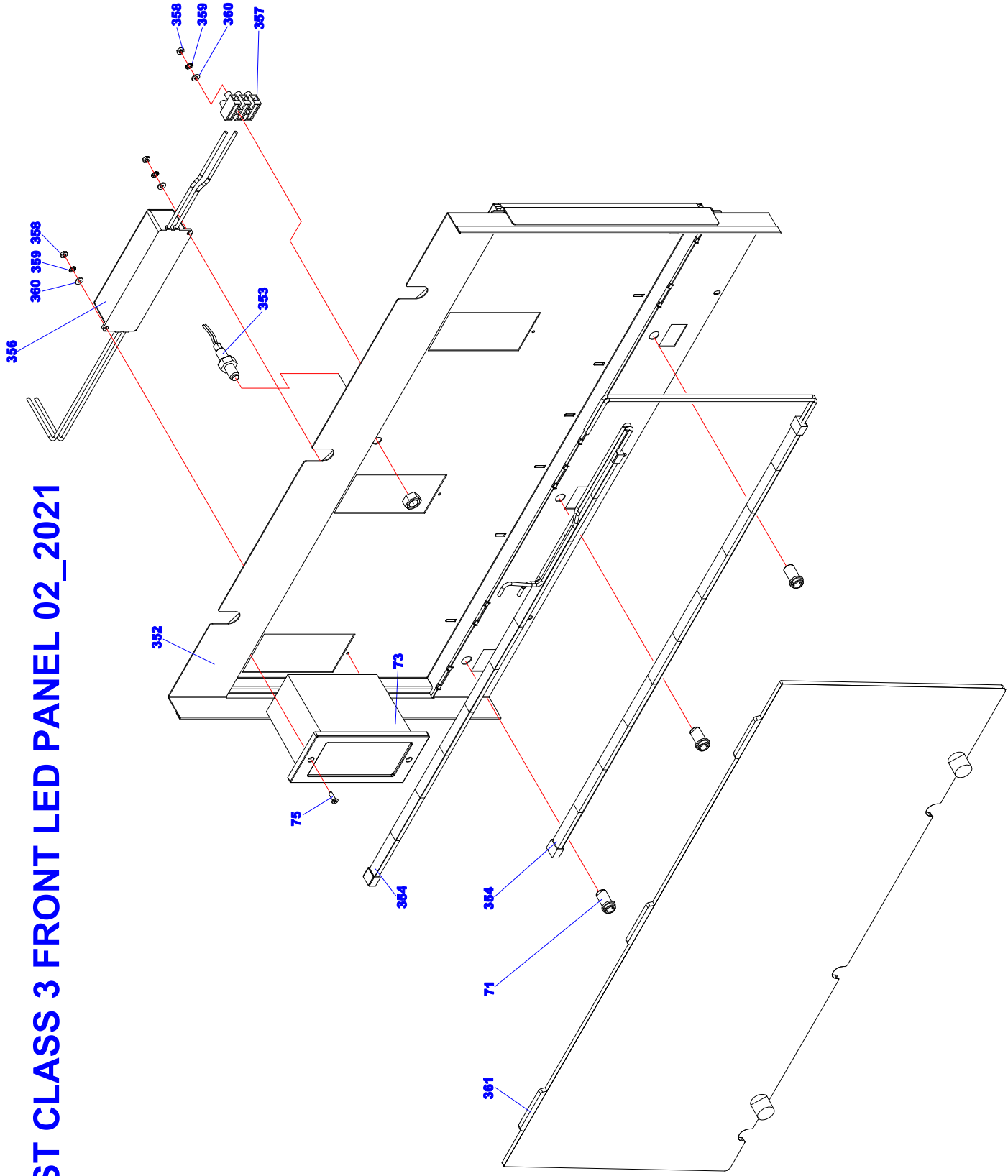

FIRST CLASS WATER 02\_2021

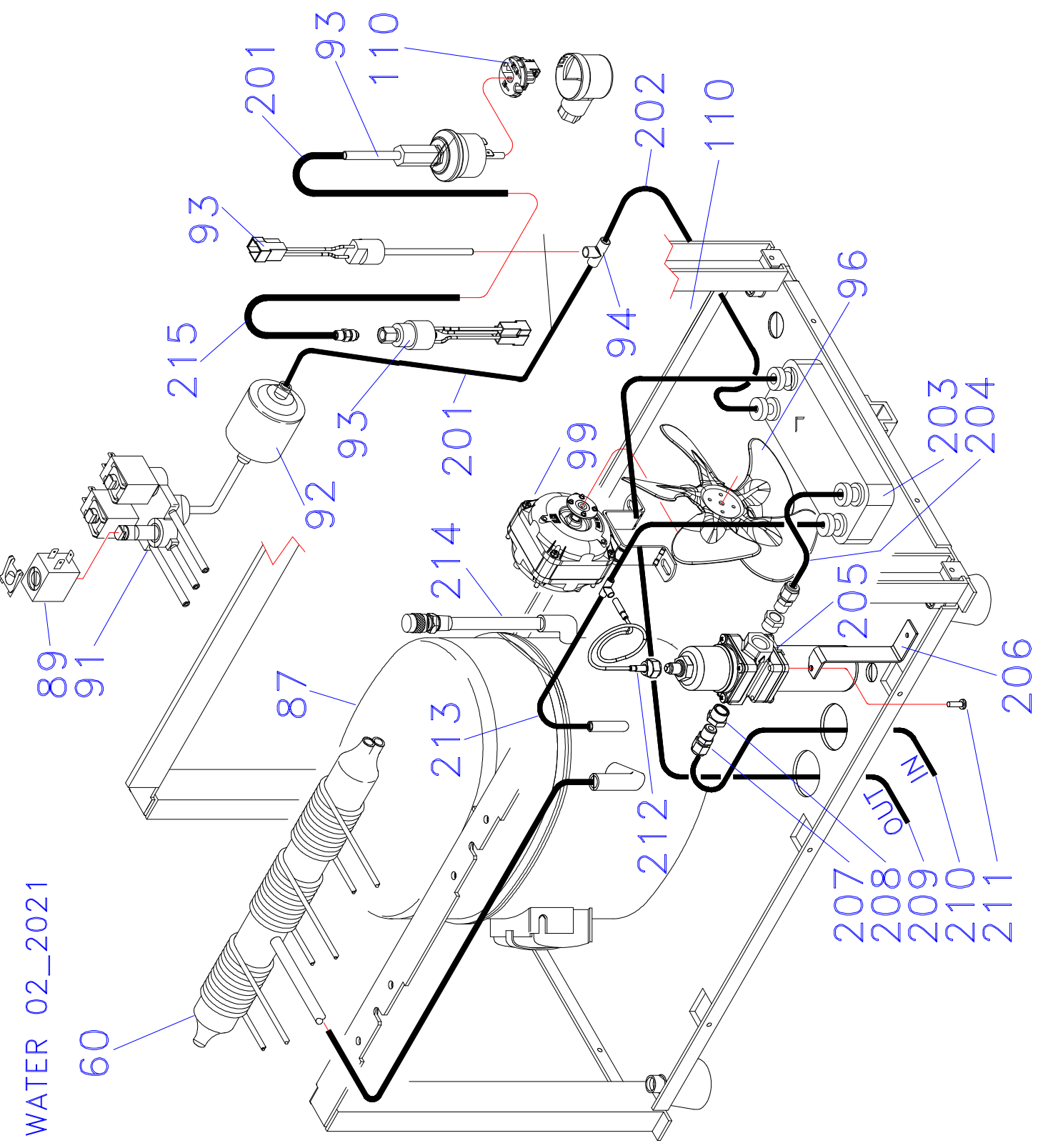

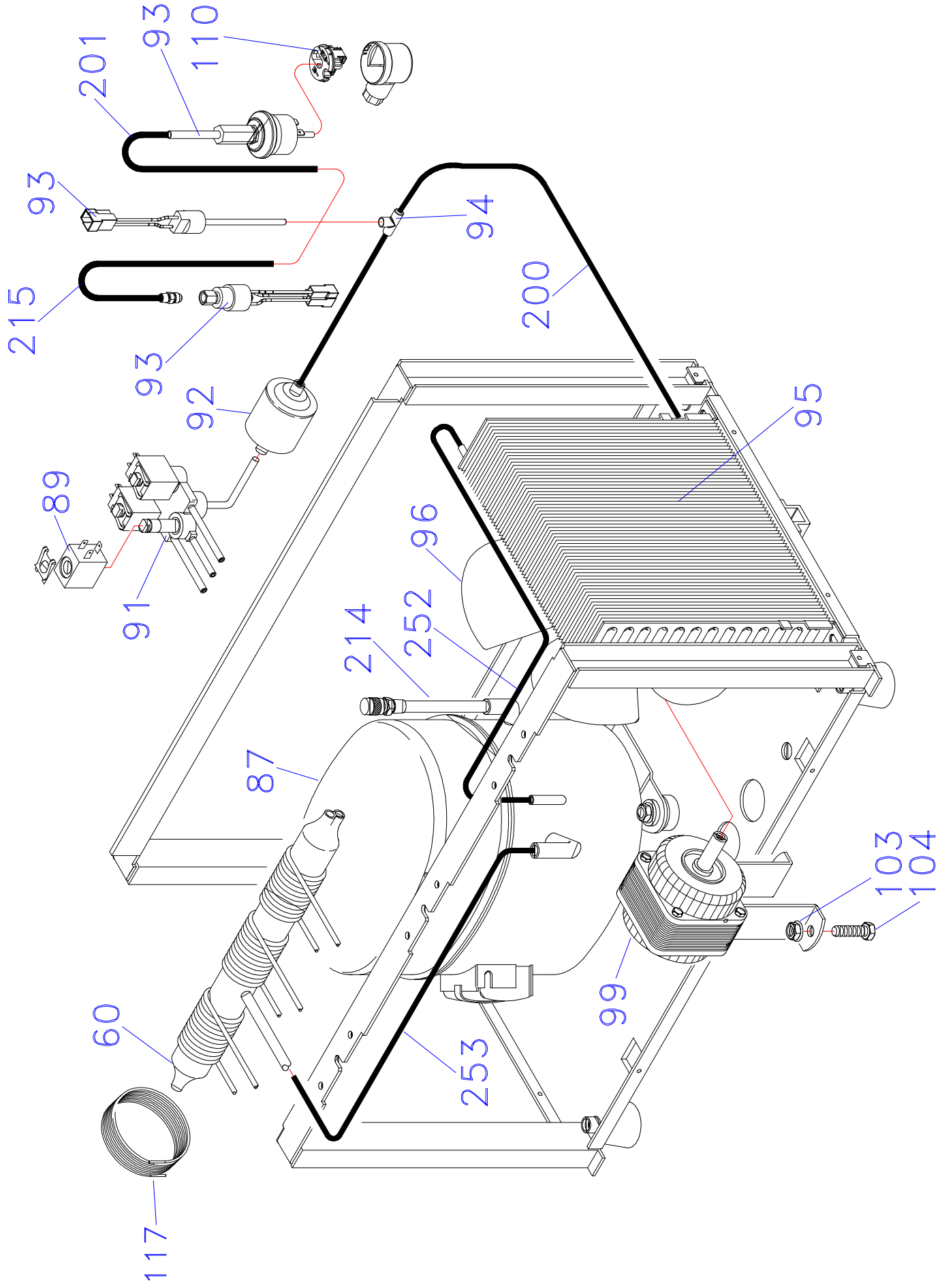

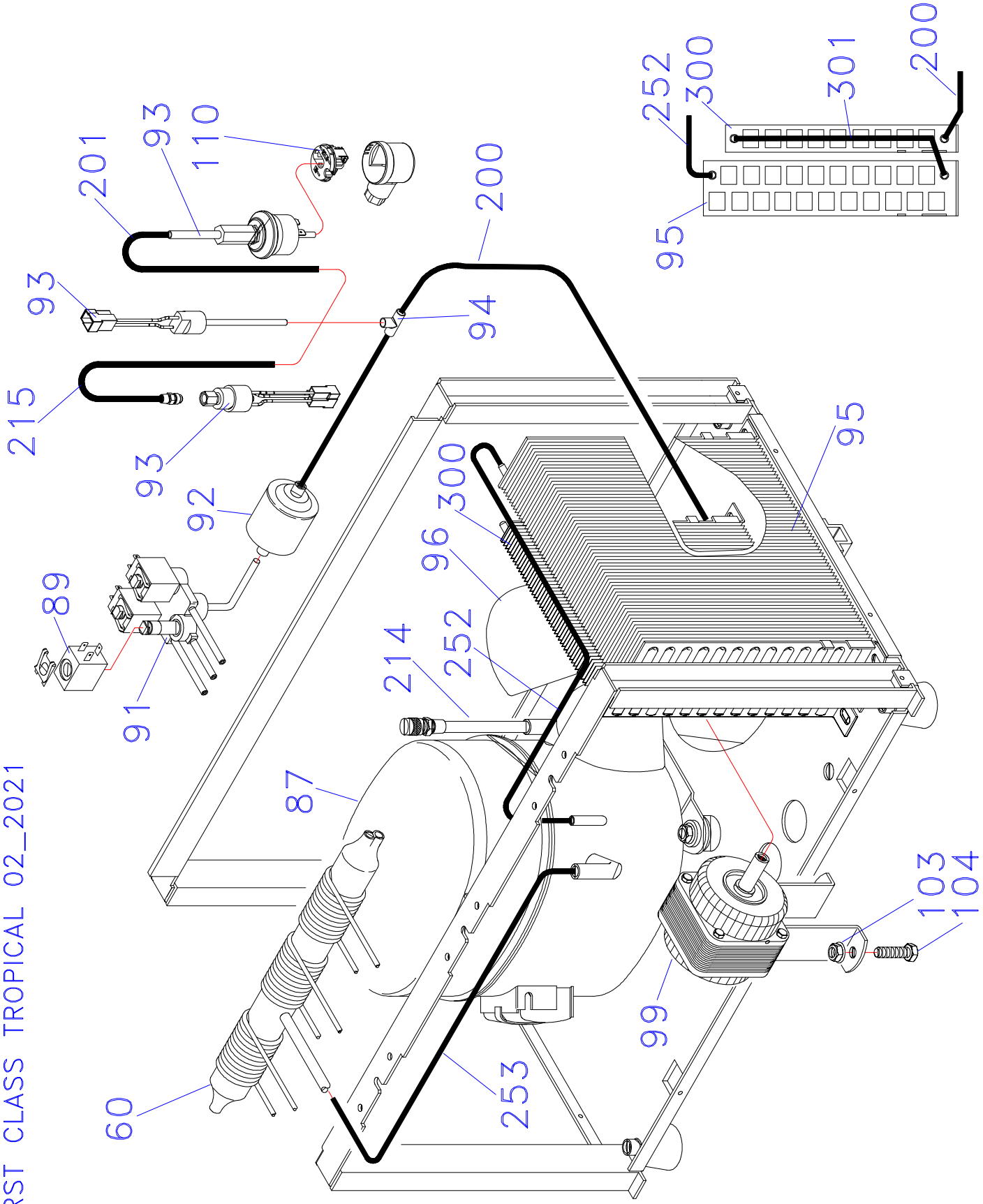

ADDITIONAL 10\$ FEE FOR ORDERS UNDER \$100 WILL BE APPLIED

PART#	Exploded View	DESCRIPTION	FC1	FC2	FC3	115/60	
M0004109-002	1	RING NUT HORIZONTAL AUGER 2012 VERSION	*	*	*	*	
M0003126-005	2	RING NUT LEVER COVER PISTON 2 ORING FV (GLASS FABER)	*	*	*	*	
M0003139-001	3	BLACK HANDLE AND COVER 2012 VERSION	*	*	*	*	
A0006111-001	4	"PULL HERE" STICKER	*	*	*	*	
OR13000117	6	O-RING 117	*	*	*	*	
M0003117-001	9	OUTLET BACK GASKET	*	*	*	*	
M0006134-001	12	DISPENSING SPOUT	*	*	*	*	
M0006134-002	12	DISPENSING SPOUT CUP VERSION	*	*	*	*	
M0000106-001	13	GASKET TRANSPARENT TANK	*	*	*	*	
M0000147-001	14	TRANSPARENT TANK	*	*	*	*	
M0005159-001	15	LOW VOLTAGE CONTACT WIRES KIT	*	*	*	*	
M0006108-001	17	LAMP GLASS	*	*	*	*	
MG005101-001	18	9 LED LAMP 12VAC/24VDC	*	*	*	*	
VTTTC2.9X9.5CR	20	SCREW TC 2.9X9.5	*	*	*	*	
M0005109-001	21	12V CONTACT FOR TANK	*	*	*	*	
M0006129-001	22	PLASTIC LENS STICKER	*	*	*	*	
M0006193-004	24	BLACK LID NEW	*	*	*	*	
M0006193-005	24	YELLOW LID NEW	*	*	*	*	
M0006193-006	24	BLUE LID NEW	*	*	*	*	
M0006193-008	24	WHITE LID NEW	*	*	*	*	
M0006125-019	27	KEC BLACK TOP LIGHT COVER COMPLETE	*	*	*	*	
M0006125-017	27	BLACK TOP LIGHT COVER COMPLETE NO STICKERS	*	*	*	*	
M0006125-013	27	NESTLE' BLU TOP LIGHT COVER COMPLETE	*	*	*	*	
M0006125-018	27	BLU TOP LIGHT COVER COMPLETE NO STICKERS	*	*	*	*	
M0006125-005	27	BLACK TOP LIGHT COVER COMPLETE	*	*	*	*	
M0006125-007	27	SLUSH PUPPIE CANADA TOP LIGHT COVER COMPLETE	*	*	*	*	
M0006125-008	27	YELLOW TOP LIGHT COVER COMPLETE	*	*	*	*	
M0006125-012	27	BLU TOP LIGHT COVER COMPLETE	*	*	*	*	
M00061129-001	27	BLACK TOP LIGHT COVER COMPLETE NO STICKER	*	*	*	*	
M0000107-001	28	FC/BB RING NUT VERTICAL PROPELLER	*	*	*	*	
M0000108-001	29	TRANSMISSION SHAFT WITH NUT	*	*	*	*	
M0004111-002	30	VERTICAL AUGER COMPLETE OF BUSHING	*	*	*	*	
M0004104-001	32	PINION VERTICAL AUGER UNTIL S/N 140502075	*	*	*	*	
M0004104-002	32	PINION VERTICAL AUGER FROM S/N 140502076	*	*	*	*	
M0000104-001	33	BUSHING TRANSMISSION SHAFT	*	*	*	*	

ADDITIONAL 10\$ FEE FOR ORDERS UNDER \$100 WILL BE APPLIED

PART#	Exploded View	DESCRIPTION	FC1	FC2	FC3	115/60	
M0000161-002	34	TRANSMISSION SHAFT WITH SLEEVE+ORING 2014 VERSION	*	*	*	*	
A0001104-001	35	GEAR MOTOR/TRANSMISSION SHAFT PIN	*	*	*	*	
A0000114-001	36	TRANSMISSION SHAFT ORING 2012 VERSION	*	*	*	*	
M0000114-001	36	TRANSMISSION SHAFT FLAT GASKET	*	*	*	*	
M0005117-004	37	BLACK TERMINAL BOARD COMPLETE	*	*	*	*	
M0006103-003	38	BLACK REAR HINGE	*	*	*	*	
M0000120-001	39	M5 SQUARE NUT	*	*	*	*	
M0001101-001	40	SCREW TE 5X12MM	*	*	*	*	
M0000105-001	41	RING NUT SHAFT FASTENING	*	*	*	*	
M0002112-007	42	BLACK COMPLETE INOX TANK	*	*	*	*	
M0000157-002	43	ELECTRONIC THERMOSTAT PROBE COMPLETE	*	*	*	*	
M0004105-002	45	HORIZONTAL AUGER GEAR	*	*	*	*	
M0004110-002	46	HORIZONTAL AUGER COMPLETE OF BUSHING 2012 VERS.	*	*	*	*	
M0006116-003	47	BLACK BASE	*	*	*	*	
M0006102-003	48	BLACK HINGE HOOK	*	*	*	*	
M0006115-003	49	BLACK FRONT HINGE	*	*	*	*	
M0006119-001	50	LOCKING BOLT	*	*	*	*	
M0000122-001	52	SCREW 6X12	*	*	*	*	
M0102112-001	60	FC1 ACCUMULATOR	*			*	
BOYLERM2CAP	60	FC2 ACCUMULATOR (3MTX1.06MM)		*		*	
BOYLERM3CAP	60	FC3 ACCUMULATOR (5MTX1.06MM)			*	*	
M0006112-001	61	BACK STAINLESS STEEL PANEL WITH LOUVERS		ST_ALL ML_A ML_W GREEN G404	ST_ALL ML_A ML_W GREEN G404	*	
M0106108-001	61	BACK STAINLESS STEEL PANEL WITH HOLES - FC1	*			*	
M0006124-001	62	SCREW 3.9X9.5	*	*	*	*	
M0006192-004	63	KIT PLASTIC PANEL RIGHT\LEFT BLACK	*	*	*	*	
M0006192-005	63	KIT PLASTIC PANEL RIGHT\LEFT YELLOW	*	*	*	*	
M0006192-006	63	KIT PLASTIC PANEL RIGHT\LEFT BLUE	*	*	*	*	
M0006192-010	63	KIT PLASTIC PANEL RIGHT\LEFT WHITE	*	*	*	*	
M0006113-001	64	RIGHT SIDE STAINLESS STEEL PANEL WITH LOUVERS	ML_A GREEN G404	ML_W	ML_W	*	
M0006126-001	64	RIGHT SIDE STAINLESS STEEL PANEL (CONDENSER SIDE)		ML_A GREEN G404	ML_A GREEN G404	*	
M0006159-001	64	RIGHT SIDE PANEL WITH HOLES (CONDENSER SIDE) - 42°C	ML_TR	ML_TR	ML_TR	*	
A0006102-001	65	KNOB SIDE PANEL		*	*	*	

ADDITIONAL 10\$ FEE FOR ORDERS UNDER \$100 WILL BE APPLIED

PART#	Exploded View	DESCRIPTION	FC1	FC2	FC3	115/60	
M0006198-001	68	LEFT SIDE PANEL WITH LOUVERS AND MAIN SWITCH+PRESSURE SWITCH LIGHT	ML_A	ML_A ML_W	ML_A ML_W	*	
I82L2206165	69	MAIN SWITCH	*	*	*	*	
TSC8X11	70	DRAIN SILICON TUBE f 8X11MM	*	*	*	*	
B06.031C	71	DRAIN PLASTIC CONNECTION	*	*	*	*	
A0005105-001	72	COMPRESSOR WARNING RED LIGHT 115V	ST_ALL ML_ALL	ST_ALL ML_ALL	ST_ALL ML_ALL	*	
A0005105-002	72	GREEN LIGHT WARNING COMPRESSOR 110V	GREEN G404	GREEN G404	GREEN G404	*	
M0005167-001	73	MILLENNIUM ELECTRONIC BOARD ENGLISH	ML_ALL	ML_ALL	ML_ALL	*	
M0005167-002	73	MILLENNIUM ELECTRONIC BOARD SPANISH	ML_ALL	ML_ALL	ML_ALL	*	
M0005167-006	73	MILLENNIUM ELECTRONIC BOARD ENGLISH - LEVITT	ML_ALL	ML_ALL	ML_ALL	*	
M0005166-001	73	FC GREEN ELECTRONIC BOARD ENGLISH	GREEN G404	GREEN G404	GREEN G404	*	
M0005166-002	73	FC GREEN ELECTRONIC BOARD SPANISH	GREEN G404	GREEN G404	GREEN G404	*	
M0105101-001	74	FC1 STANDARD ELECTRICAL WIRING	ST_ALL			*	
M0205101-001	74	FC2 STANDARD ELECTRICAL WIRING		ST_ALL		*	
M0305101-001	74	FC3 STANDARD ELECTRICAL WIRING			ST_ALL	*	
M0105103-001	74	MILLENNIUM ELECTRICAL WIRING FC1	ML_ALL			*	
M0205103-002	74	MILLENNIUM ELECTRICAL WIRING FC2		ML_ALL		*	
M0305103-002	74	MILLENNIUM ELECTRICAL WIRING FC3			ML_ALL	*	
M0105104-001	74	FC1 GREEN ELECTRICAL WIRING	GREEN G404			*	
M0205104-001	74	FC2 GREEN ELECTRICAL WIRING		GREEN G404		*	
M0305105-001	74	FC3 GREEN ELECTRICAL WIRING			GREEN G404	*	
M0005135-001	75	SCREW 2.9X9.5	*	*	*	*	
M0006111-002	76	STAINLESS STEEL FRONT PANEL	*	*	*	*	
A0006140-001	77	KIT BLACK DRIP TRAY+ BLACK PLASTIC DRIP TRAY FC-BB	ALL	*	*	*	
M0005127-003	79	ELECTR. FC MILL + KIT UPGRADE STD	ST_ALL	ST_ALL	ST_ALL	*	
A5405102-001	80	RELAY NEK2125GK 115V/60HZ-100V/50HZ 2283039	ST_ALL ML_ALL			*	
M5605101-001	80	RELAY NT2178GK 115V/60HZ 1253050		ST_ALL ML_ALL	ST_A ST_W ML_A ML_W	*	
A5405105-001	80	RELAY NEK2134U 115V R290 2271155	GREEN			*	
A5605105-001	80	RELAY NEU2168U 115V R290 1253069		GREEN	GREEN	*	
COND2252096	81	START CAPACITOR NE2125GK 115V/60Hz-100V/50HZ	ST_ALL ML_ALL			*	



ADDITIONAL 10\$ FEE FOR ORDERS UNDER \$100 WILL BE APPLIED

PART#	Exploded View	DESCRIPTION	FC1	FC2	FC3	115/60	
M5605104-001	81	RUN CAPACITOR NT2178GK 115V/60HZ 2253315		ST_ALL ML_ALL	ST_A ST_W ML_A ML W	*	
A5405103-001	81	START CAPACITOR NEK2125GK 115V/60HZ-100V/50HZ 2252217	ST_ALL ML_ALL			*	
M5605103-001	81	START CAPACITOR NT2178GK 115V/60HZ 2252273		ST_ALL ML_ALL	ST_A ST_W ML_A ML W	*	
A5405106-001	81	START CAPACITOR NEK2134U115V R290 2252324	GREEN			*	
A5605106-001	81	START CAPACITOR NEU2168U115VR290 2252300		GREEN	GREEN	*	
A5605107-001	81	RUN CAPACITOR NEU2168U 115V R290 2253314		GREEN	GREEN	*	
M5605102-001	82	THERMAL PROTECTOR NT2178GK 115V/60HZ 2291058		ST_ALL ML_ALL	ST_A ST_W ML_A ML W	*	
A5405101-001	82	THERMAL PROTECTOR NEK2125GK 115V/60HZ-100V/50HZ 2321080	ST_ALL ML_ALL			*	
A5405104-001	82	OLP THERMAL PROTECTOR NEK2134U 115V R290 2324063	GREEN			*	
A5605104-001	82	OLP THERMAL PROTECTOR NEU2168U 115V R290 2321081		GREEN	GREEN	*	
CAVOAL.UL15ALAV	83	POWER CORD 115 V U.L. FOR USA	*	*	*	*	
M0005112-001	85	CONNECTION FOR SUPPLYING WIRING	*	*	*	*	
A0005112-001	86	TRANSFORMER 60VA 115- 230/12Vac	ST_ALL ML_ALL	ST_ALL ML_ALL	ST_ALL ML_ALL	*	
A5402101-001	87	NEK2125GK 115V/60HZ- 100V/50HZ COMPRESSOR	ML_A			*	
M5602101-001	87	COMPRESSOR NT2178GK 115/60 922EG0204AF CSCR		ST_ALL ML_ALL	ST_A ST_W ML_A ML W	*	
A5402104-001	87	COMPR. NEK2134U 115/60 862AG71M9AJ	GREEN			*	
M5602104-001	87	COMPRESSOR NEU2168U 115/60 CSR		GREEN	GREEN	*	
F11584	88	FUSE 5A 5X20	*	*	*	*	
AA005102-001	89	OLAB COIL 120/50-60 UL 11000BH/G6IU-2	*	*	*	*	
A0005103-001	90	FUSE F315MA 5X20	*	*	*	*	
A0102103-002	91	OLAB 1 WAY BODY VALVE	*			*	
A0302101-002	91	OLAB 3 WAY BODY VALVE NC DN1,2 K09122-A			*	*	
A0202102-002	92	OLAB 2 WAY BODY VALVE		*		*	
A0002113-001	92	DRYER	*			*	
M0602115-001	92	DRYER SOLID CORE		*	*	*	

ADDITIONAL 10\$ FEE FOR ORDERS UNDER \$100 WILL BE APPLIED

PART#	Exploded View	DESCRIPTION	FC1	FC2	FC3	115/60	
A0002101-001	93	R404A PRESSURE SWITCH G63P5081600	ST_ALL ML_ALL G404	ST_ALL ML_ALL G404	ST_ALL ML_ALL G404	*	
A0002123-002	93	R404A PRESSURE SWITCH NSDHM00D12100	ST_ALL ML_ALL G404	ST_ALL ML_ALL G404	ST_ALL ML_ALL G404	*	
A0002122-002	93	R290 PRESSURE SWITCH NSDHA11B13101	GREEN	GREEN	GREEN	*	
TEEDIRAMED6	94	D.6 CUPPER TEE	*	*	*	*	
C082036007	95	IRON CONDENSER STFT 16224		ST_A ML_A	ST_A ML_A	*	
M0102111-001	95	IRON CONDENSER STFT 14T 2R 145A" FC1	ML_A			*	
M0602103-001	95	IRON CONDENSER STFT 18224/245		ST_TR ML_TR	ST_TR ML_TR	*	
M0102110-001	96	ALUMINUM FAN BLADE 172/34°	ML_A			*	
V4012016M3/2	96	ALUMINUM FAN BLADE 254/31°			ST_A ML_A	*	
V4012016M3/2	96	ALUMINUM FAN BLADE 254/31°		ST_TR ML_TR	ST_TR ML_TR	*	
V4012201M3WBM	96	ALUMINUM FAN BLADE 200/34°		ST_W ML_W	ST_W ML_W	*	
A5605102-001	99	FAN MOTOR 82UL-3016/29 115V/60HZ		ST_A ML_A	ST_A ML_A	*	
A5605102-001	99	FAN MOTOR 82UL-3016/29 115V/60HZ		ST_TR ML_TR	ST_TR ML_TR	*	
A5005101-001	99	FAN MOTOR 82UL-2009/32 115V/60HZ	ML_A			*	
A5005101-001	99	FAN MOTOR 82UL-2009/32 115V/60HZ		ST_W ML_W	ST_W ML_W	*	
LA105103-001	99	ELECTRONIC FAN 17231ABT 110V UL 150*38	GREEN G404			*	
A5605103-001	99	ELECTRONIC FAN MOTOR 20WR 115V EC205B000000		GREEN G404	GREEN G404	*	
M0001104-001	100	DRIP TRAY BRACKET	*	*	*	*	
PAR114-ELGR	101	SMALL RUBBER FEET	*	*	*	*	
A5601101-001	102	U.S.A. FEET		*	*	*	
DADOD.6ZFL	103	M6 NUT	*			*	
DADOD.8ZFL	103	M8 NUT		*	*	*	
VTTE6X12Z	104	SCREW 6X12	*			*	
VTTE8X16Z	104	SCREW 8X16		*	*	*	
M0005134-001	105	BOARD BOX	*	*	*	*	
M0003130-001	107	OUTLET RESTRICTION	*	*	*	*	
M0000144-001	109	WASHER FOR GEAR MOTOR'S SCREW D.6,3	*	*	*	*	
A0005110-001	110	PRESSURE SWITCH CONNECTION WIRES for A0002101-001	*	*	*	*	
M0000124-001	111	CONNECTION WIRES COVERING BAG	*	*	*	*	
M0005142-001	112	ELECTRICAL KIT OF CONDENSERS FOR POWER FACTOR IMPROVEMENT			*	*	
M0005141-001	113	CONDENSER FOR POWER FACTOR IMPROVEMENT			*	*	
A0006103-001	115	MAXIMUM LEVEL STICKERS	*	*	*	*	

ADDITIONAL 10\$ FEE FOR ORDERS UNDER \$100 WILL BE APPLIED

PART#	Exploded View	DESCRIPTION	FC1	FC2	FC3	115/60	
A0002105-001	117	FC1 CAPILLARY 0,91MMX2,75MT	*			*	
M0005151-001	118	POWER CORD SCREW TERMINAL BOARD	*	*	*	*	
C0005101-001	121	OPTICAL/MAGNETIC READER WIRE	ST_A	ST_A	ST_A	*	
B1071234	122	MAGNET SLEEVE ***FOR ELCO GEAR MOTOR ONLY FROM PROD. 40-06***	ST_ALL ML-ALL	ST_ALL ML-ALL	ST_ALL ML-ALL	*	
M1551004	123	PERMANENT MAGNET ***FOR ELCO GEAR MOTOR ONLY FROM PROD. 2002***	ST_ALL ML-ALL	ST_ALL ML-ALL	ST_ALL ML-ALL	*	
A0000123-002	124	KIT COMPLETE PLASTIC COVER WITH HALL CELL ELCO	ST_ALL ML-ALL	ST_ALL ML-ALL	ST_ALL ML-ALL	*	
C025006	124	HALL CELL KENTA	ST_ALL ML-ALL	ST_ALL ML-ALL	ST_ALL ML-ALL	*	
M0005139-003	125	COMPLETE GEAR MOTOR WITH HALL SENSOR KENTA	ST_ALL ML-ALL	ST_ALL ML-ALL	ST_ALL ML-ALL	*	
M0005139-002	125	COMPLETE GEAR MOTOR WITH HALL SENSOR ELCO	ST_ALL ML-ALL	ST_ALL ML-ALL	ST_ALL ML-ALL	*	
M0004102-002	126	HORIZONTAL AUGER BUSHING 2012 VERS.	*	*	*	*	
A0000117-001	127	GEAR MOTOR BUSHING	*	*	*	*	
A0000115-001	128	SCREW TE M5X20MM	*	*	*	*	
M0003138-001	129	HANDLE FOR DISABLE PEOPLE	*	*	*	*	
M0004102-001	130	HORIZONTAL AUGER BUSHING	*	*	*	*	
M0106124-001	131	FC1 BACK PANEL FOR AIR FILTER	*			*	
M0106127-001	132	FC1 REMOVABLE AIR FILTER	*			*	
M0106128-001	133	KIT PANEL+AIR FILTER FOR FC1	*			*	
M0606117-001	134	FC2 FC3 AIR FILTER		*	*	*	
M0606116-001	135	FC2 FC3 SIDE RIGHT PANEL FOR AIR FILTER		*	*	*	
M0606118-001	136	KIT PANEL+AIR FILTER FC2/3		*	*	*	
A0005106-001	164	MOLEX CONNECTOR FOR MAIN SWITCH	*	*	*	*	
M5602102-001	200	KIT COPPER PIPE D.6MM AIR CONDENSER-TEE-FILTER FC2/3		ST_A ST_TR ML_A ML TR	ST_A ST_TR ML_A ML TR	*	
M0102121-001	200	KIT COPPER PIPE D.6MM AIR CONDENSER-TEE-FILTER FC1	*			*	
M0102114-001	201	COPPER PIPE D.6MM TEE - PRESSOSTAT SWITCH A0002101-001	ST_ALL ML_ALL G404	ST_ALL ML_ALL G404	ST_ALL ML_ALL G404	*	
M0602114-001	202	KIT COPPER PIPE D.6MM WATER CONDENSER-TEE-FILTER FC2W/3W		ST_W ML_W	ST_W ML_W	*	
CB5X8M2/3W	203	WATER CONDENSER		ST_W ML_W	ST_W ML_W	*	
M0602107-001	204	PRESSURE SWITCH VALVE COPPER PIPE D.8 -AIR CONDENSER		ST_W ML_W	ST_W ML_W	*	
A0602102-001	205	PRESSURE SWITCH VALVE WVFX1025		ST_W ML_W	ST_W ML_W	*	

ADDITIONAL 10\$ FEE FOR ORDERS UNDER \$100 WILL BE APPLIED

PART#	Exploded View	DESCRIPTION	FC1	FC2	FC3	115/60	
A0600101-001	206	PRESSURE SWITCH VALVE SUPPORT		ST_W ML_W	ST_W ML_W	*	
NIPLES+RACCOR	207	BRASS NIPLES 1/4" D.8MM		ST_W ML_W	ST_W ML_W	*	
M0602108-001	209	WATER OUTPUT COPPER PIPE D.8MM		ST_W ML_W	ST_W ML_W	*	
M0602106-001	210	WATER INPUT COPPER PIPE D.8MM		ST_W ML_W	ST_W ML_W	*	
VTTTC5X16CRIN	211	SHAFT FASTENING SCREW - PRESSURE SWITCH VALVE		ST_W ML_W	ST_W ML_W	*	
M0602110-001	212	CAPILLARY COPPER PIPE TEE - PRESSURE SWITCH VALVE		ST_W ML_W	ST_W ML_W	*	
M0602113-001	213	KIT COPPER PIPE D.6MM COMPRESSOR-TEE-WATER CONDENSER FC2W/3W		ST_W ML_W	ST_W ML_W	*	
A0002112-001	214	CHARGE VALVE +COPPER PIPE D.6MM 26,5CM FC2/3		*	*	*	
A0002111-001	214	CHARGE VALVE +COPPER PIPE D.6MM 16,5CM FC1	*			*	
M0002113-001	215	COPPER PIPE D.6MM TEE - PRESSOSTAT SWITCH A0002123-002	ST_ALL ML_ALL G404	ST_ALL ML_ALL G404	ST_ALL ML_ALL G404	*	
M0202102-001	252	COMPRESSOR COPPER PIPE D.6MM - AIR CONDENSER		ST_A ST_TR ML_A ML TR	ST_A ST_TR ML_A ML TR	*	
M0102103-001	252	COMPRESSOR COPPER PIPE D.6MM - AIR CONDENSER	*			*	
M0102107-001	253	BOYLER COPPER PIPE D.6MM - COMPRESSOR	*			*	
M0000150-001	350	MACHINE MODULE SHAFT	ML_ALL GREEN G404	ML_ALL GREEN G404	ML_ALL GREEN G404	*	
M0005168-001	351	GREEN-MILLENIUUM "MACHINE MODULE"	*	*	*	*	
M0306140-001	352	KIT FRONT PANEL FC3 AISI430+ALLUM.			ML_A GREEN G404	*	
B0005105-001	353	SENSOR REED MEDER MK11/M8-BV14649		ML_A GREEN G404	ML_A GREEN G404	*	
M0306137-001	354	STRIP LED 24VDC 500MM 120LED/M IP67			ML_A GREEN G404	*	
A0005121-001	356	SWITCHING POWER SUPPLY 100-240/24 LPV-20-24		ML_A GREEN G404	ML_A GREEN G404	*	
M93CSGRFB	357	CONNECTION FOR WIRING PA10HDS 12P		ML_A GREEN G404	ML_A GREEN G404	*	
DADOD.3Z	358	M3 NUT		ML_A GREEN G404	ML_A GREEN G404	*	

ADDITIONAL 10\$ FEE FOR ORDERS UNDER \$100 WILL BE APPLIED

PART#	Exploded View	DESCRIPTION	FC1	FC2	FC3	115/60	
ROND.D.3.2EDENT	359	WASHER D.3,2		ML_A GREEN G404	ML_A GREEN G404	*	
ROND.D.3ZPIANA	360	WASHER D.3		ML_A GREEN G404	ML_A GREEN G404	*	
M0306135-001	361	FRONT GRAPHIC PANNEL FC3 BLU BEVERAGE			ML_A GREEN G404	*	
M0306135-002	361	FRONT GRAPHIC PANNEL FC3 NO GRAPHIC			ML_A GREEN G404	*	
M0306135-003	361	FRONT GRAPHIC PANNEL FC3 SLUSH PUPPIE			ML_A GREEN G404	*	
M0206135-001	362	KIT FRONT PANEL FC2 AISI430+ALLUM.		ML_A GREEN G404		*	
M0206136-001	363	STRIP LED FC2 24VDC 350MM 120LED/M IP67		ML_A GREEN G404		*	
M0206133-002	364	FRONT GRAPHIC PANNEL FC2 NO GRAPHIC		ML_A GREEN G404		*	
M0206138-001	365	THICKNESS behind E-BOARD		ML_A GREEN G404		*	
VTTC2.9X13CR	366	SCREW TSP 2.9X16		ML_A GREEN G404		*	
A0005122-002	400	BRUSHLESS GEAR MOTOR	GREEN G404	GREEN G404	GREEN G404	*	
AA005101-002	401	COMPRESSOR POWER RELAY 115V ATEX		GREEN G404	GREEN G404	*	
B0005134-001	402	POWER SWITCHING 100-240/24 LRS150-24		GREEN G404	GREEN G404	*	
A0105101-001	402	POWER SWITCHING 100-240/24 LRS 50-24	GREEN G404			*	
L0201110-001	403	FIXING BRACKETS	GREEN G404	GREEN G404	GREEN G405	*	
A0005116-001		KIT WIRES. PRESSOSTAT G63 + Terminals Locking Fork	ST_ALL ML-ALL	ST_ALL ML-ALL	ST_ALL ML-ALL	*	
M0106103-002			*			*	
M0206103-002				*		*	
M0306103-002					*	*	